

THE ARK OF THE COVENANT & MERCY SEAT

Exodus 25: 10-22
Exodus 37: 1-9

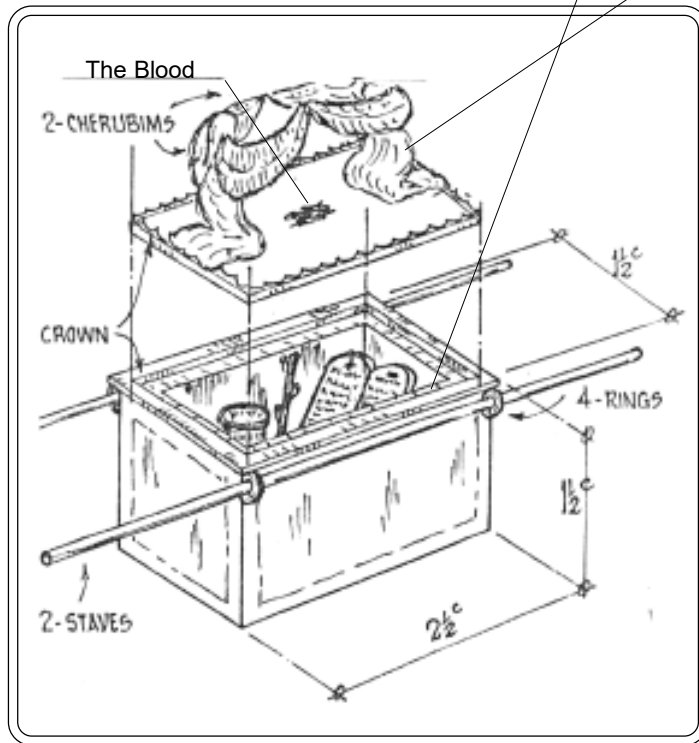

THE SEVEN ITEMS OF FURNITURE in the Tabernacle are seven stepping stones that take us to our destiny . . . of being Like Jesus and sitting experientially with Him on His Throne.

The **ARK OF THE COVENANT** — also known as the ARK of the Testimony (THE testimony is simply, **JESUS IS LORD**. . . not was . . . not will be . . . but IS) — is item No. 6 as is Man's ultimate vision.

The **MERCY SEAT** is No.7 and it is **GOD HIMSELF** ruling all things. . . the God that is all in all.

SEEING HIM AS THE LORD: I Cor. 15:28

And when all things shall be subdued unto him, then shall the Son also himself be subject unto him that put all things under him, that God may be all in all.

We shall look at the **ARK** itself and then what is in it.

THE SIZES ARE GIVEN

2 1/2c LONG which is HALF of (5). GRACE is (5) and for Grace to be fully effective, there are two parts or aspects. The GIVING of grace and the RECEIVING of grace.

Here the 2 1/2c of the **MERCY SEAT** = the GIVING half of grace with its purpose TO ACCOMPLISH and the 2 1/2c of the **ARK** = the RECEIVING half of grace which ACCOMPLISHED.

The complete work of Grace is seen here . . . it is the picture of CHRIST-JESUS (the Mercy Seat), the HEAD of the BODY **FITTING PERFECTLY** onto the BODY (the Ark). the Source (God) and the Expression (The Body) becoming truly ONE as Jesus, the Pattern Son, showed us — John 10:30. The Head-Mercy Seat is SOLID GOLD and is all God. . . nothing of man's effort, while the Ark is made of redeemed WOOD covered over so that all of man is completely hidden.

- **THE PRESENCE OF THE LORD** is in this place. We can come boldly to this Throne of Grace because Jesus' Blood was accepted by Father and the Power of that Blood being taken into the Holiest of All, tore the veil and left it open for us. We have experienced the Throne Room on many occasions: God desires that we enter and remain in such an awareness and relationship with the King of the Kingdom.
- The **TWO CHERUBIM** witnessing (2) to the BLOOD that was placed between them. When Jesus died, His blood was brought by the Spirit to this place in the Temple (similar pattern as this Tabernacle) with such power that the Veil was torn irreparably. Every major thing that happened to Jesus has TWO witnesses.
- The **MERCY SEAT** - THRONE had a crown pattern around its perimeter depicting a ruling . . . hence a Throne with its pure ruling motives and expected achievements.

- **1½c WIDE** — Just like the GRACE (5c), so does God’s PERFECTION (3) come in two aspects or halves.

The 1½c of the Mercy Seat = God’s PERFECTION because of who He is . . . so His plans are unbeatable. His half was the provision of perfection in Jesus, the Pattern Son for His blood, as the Lamb of God, was placed on this Mercy Seat. (Hebrews 10:19). Our HALF is the being changed into that PERFECTION or Image of God from glory to glory (II Corinthians 3:18).

- **THE MERCY SEAT** is the only place made for SITTING and RESTING. It is the most ‘western’ piece of furniture . . . west = rest. It parallels the 7th Day of Genesis’ re-generation (Chapters 1 & 2) where God RESTS on the 7th. Day because He has a ‘many-membered man’ brought forth on the 6th. Day to do His work. Here we meet God ‘Face to face’ (Hb. *AL PENEH*) as being in FULL UNION with Him. . . experiencing the FULLNESS of Christ. (Ephesians 3:19). We are exhorted to enter into His rest (Hebrews 4: 4-6).

THE ARK

- The Ark is made of **WOOD** . . . man being fashioned into his destiny by God’s hand. The ARK-BODY consists of fully redeemed saints . . . not those who just claim it ‘by faith’, but rather those who have come through the dealings of God to a place of experiencing it.

The **GOLD**, which is the nature of God (or His name) is seen on the ‘inside’ and on the ‘outside’ of each.

- **THE THRONE**, as we have seen, is for A KING: this Throne is for the King of (us) kings. The operation of the Kingdom of God in unhindered fullness, is from this Throne. By faith we now are seated with Christ on that Throne, but God desires that we experience it continually.

The **ARK** (complete with the Mercy Seat) represents:

- a] The Throne of God — Hebrews 4:16 . . . we can come at any time for help here . . . but we will sit there in Him and operate His desires/commands from such a place. This is the place where Jesus said that He was going to prepare for us (John 14:1-2).
- b] The Presence of God (on the Throne) — Psalm 80:1
- c] The Glory of God revealed through the processings to bring one to this perfection (Colossians 1:27).

- **WOOD** depicts here, man who has been transformed by the renewing of his mind. . . Romans 12:1-3. The **GOLD** covering simply shows that it is **GOD ALL THE WAY**. . . on the ‘inside’ and the ‘outside’.

INSIDE THE ARK

- a] **TWO TABLETS OF STONE** on which the ten commandments were carved by Moses. . . the **LAW** which equates with the whole scripture being God’s **WORD** = God’s **WILL** and His whole **PLAN** which will be supernaturally achieved. The law is a schoolmaster (Gk. *PAIDAGOGON* = school bus-driver) to bring us to Christ — Galations 3:24.

THROUGH CALVARY, THE TEN COMMANDMENTS BECAME (to you) TEN PROMISES without changing a single word!

- b] **THE GOLDEN POT OF MANNA**. The testimony of God’s supernatural supply to accomplish His purposes. Jesus is the ‘Living Word’ and the ‘hidden manna’ is what comes to us by revelation and can be labelled ‘a secret’.

Revelation 2:17 . . .

He that hath an ear, let him hear what the Spirit saith unto the churches; TO HIM THAT OVERCOMETH will I give to eat of THE HIDDEN MANNA, and will give him a white stone, and in the stone a new name written, which no man knoweth saving he that receiveth it.

This manna was hidden behind the VEIL and only available to those who overcome the flesh battles in their processings. THIS MANNA sustains the fullness of Himself. . . Head and Body.

- c] **AARON'S ROD THAT BUDED**

Numbers 17:3, 8-10

(3) And thou shalt write Aaron's name upon the rod of Levi: for one rod shall be for the head of the house of their fathers.

(8) And it came to pass, that on the morrow Moses went into the tabernacle of witness; and, behold, the rod of Aaron for the house of Levi was budded, and BROUGHT FORTH BUDS, and BLOOMED BLOSSOMS, and YIELDED ALMONDS.

FULL FRUIT = DESTINY ACHIEVED

All God's children were represented by the respective Heads who all had an anointing and authority by reason of being who they were. The ROD of Aaron had a greater anointing and authority. The anointing that you receive when you are born from above, is great. . . but there is needed a greater anointing or release that will enable us to enter experientially the Holiest of All. Aaron's ROD was placed in the Ark as a reminder of this. This depicts the fact that God wants us all (His Body) to move in that anointing. Anything less than the 100fold anointing, will keep us in a lesser expression of Himself.

The '30fold', '60fold' and the '100fold' expressions are experienced by our yielding to the Holy Spirit in us.

(9) And Moses brought out all the rods from before the LORD unto all the children of Israel: and they looked, and took every man his rod.

(10) And the LORD said unto Moses, Bring Aaron's rod again before the testimony, to be kept for a token against the rebels; and thou shalt quite take away their murmurings from me, that they die not.

The **BODY-ARK** is one expression of His Life in us. The **LAW** (requirements) are like Father, the Pot of Manna is like Jesus, the Living Word that we feed upon and the Rod that budded is like the Holy Spirit who achieves the DESIRE through the EXPRESSION.

The **ROD** was a mark of **AUTHORITY in the ANOINTING**. It was the mark of the Priesthood (Levitical Priests in Aaron's day and Melchisedec Priesthood in Christ's day. It is also the mark of resurrection life for Aaron's rod, long dead, came back to life and budded. . . it showed new life.

- **THE ARK** was in the Tent part of the Tabernacle representing a people who are **OVERCOMERS and FIRSTFRUITS** who blaze the trail for those who follow. First comes the Order of Melchisedec and then the next order or calling and so on . . . every man in his own order (I Corinthians 15:23). The **RULING** is carried out until every effect of sin has been removed from the earth (people) (I Corinthians 15: 25,26).

I Samuel 6: 1-19

A parable for us outlining the bringing of the ARK back into our lives completely. David experienced earlier the effects of doing it the wrong way.

The question gets answered, "*How shall the Ark of the Lord come to me?*" (verse 9).